

These slides have been modified from an initial version developed by Quanser

<https://www.quanser.com>

I sincerely thank Quanser for allowing me to adapt them

When a basic feedback loop is not enough...

Some control challenges require an approach to the structure of the controller that is more complicated than the basic single feedback loop

Adding loops in various configurations can help to control more complex systems in a deterministic way

- Cascade control
- Feedforward control
- Hybrid control



Cascade Control

Cascade control is a multiloop control structure which is used when there are more than one measurements, but only one control variable is available

The inner and the outer control loops are formed, each with an individual feedback controller

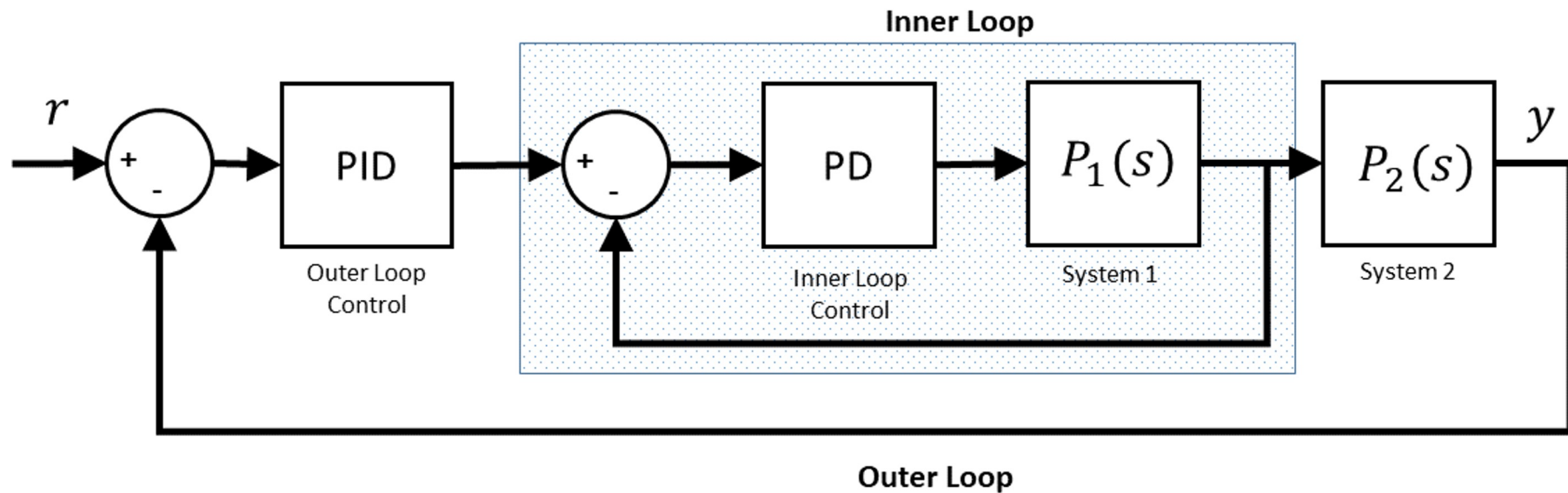

Example: Unmanned Underwater Vehicle

- Diving depth is controlled by changing the pitch angle of the vehicle using the stern plane
- Two controllers are needed, one to control the angle of the stern plane, and an outer-loop to control the pitch of the vehicle
- Another outer loop controller could be used to control the depth of the vehicle



Example: Unmanned Underwater Vehicle

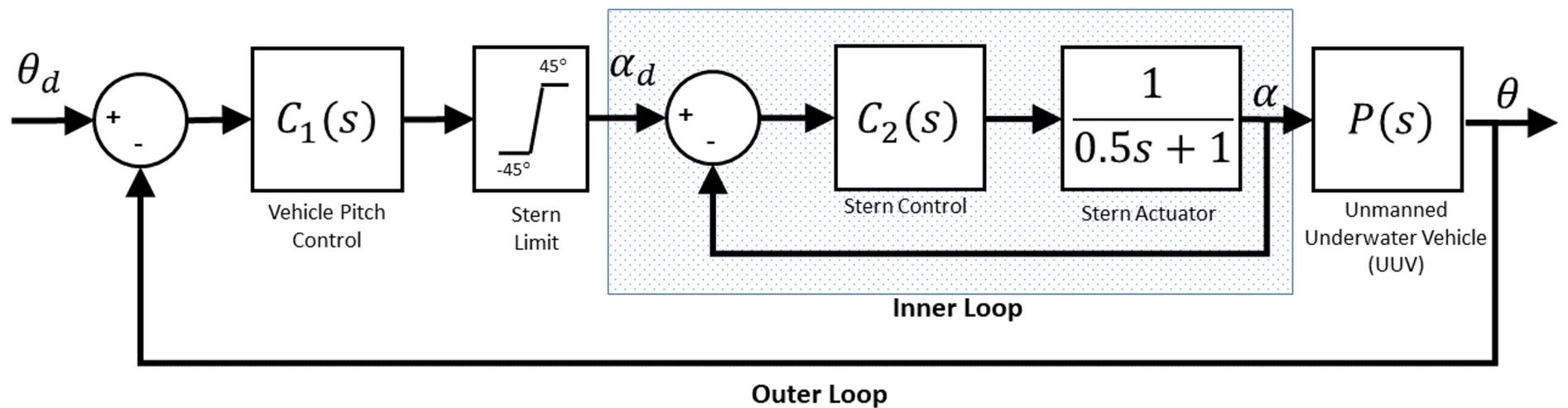

In this example an inner-loop controller is used to control the pitch of the stern plane. An outer-loop PD controller is used to control the pitch of the vehicle and feeds into the inner loop.

Takeaways - Cascade control

- is used when multiple controllers are required to control elements of a system that feed into each other
- They are often used to control actuator dynamics as well as the state of a plant simultaneously

Feedforward Control

- Feedforward control is used to compensate for elements in a system that would require a constant control action
- Feedforward is typically used either to improve the response of a system, to mitigate integral wind-up, or to compensate for disturbances
- In all cases, an accurate model of the effect of the feedforward element on the system is needed

Feedforward Control

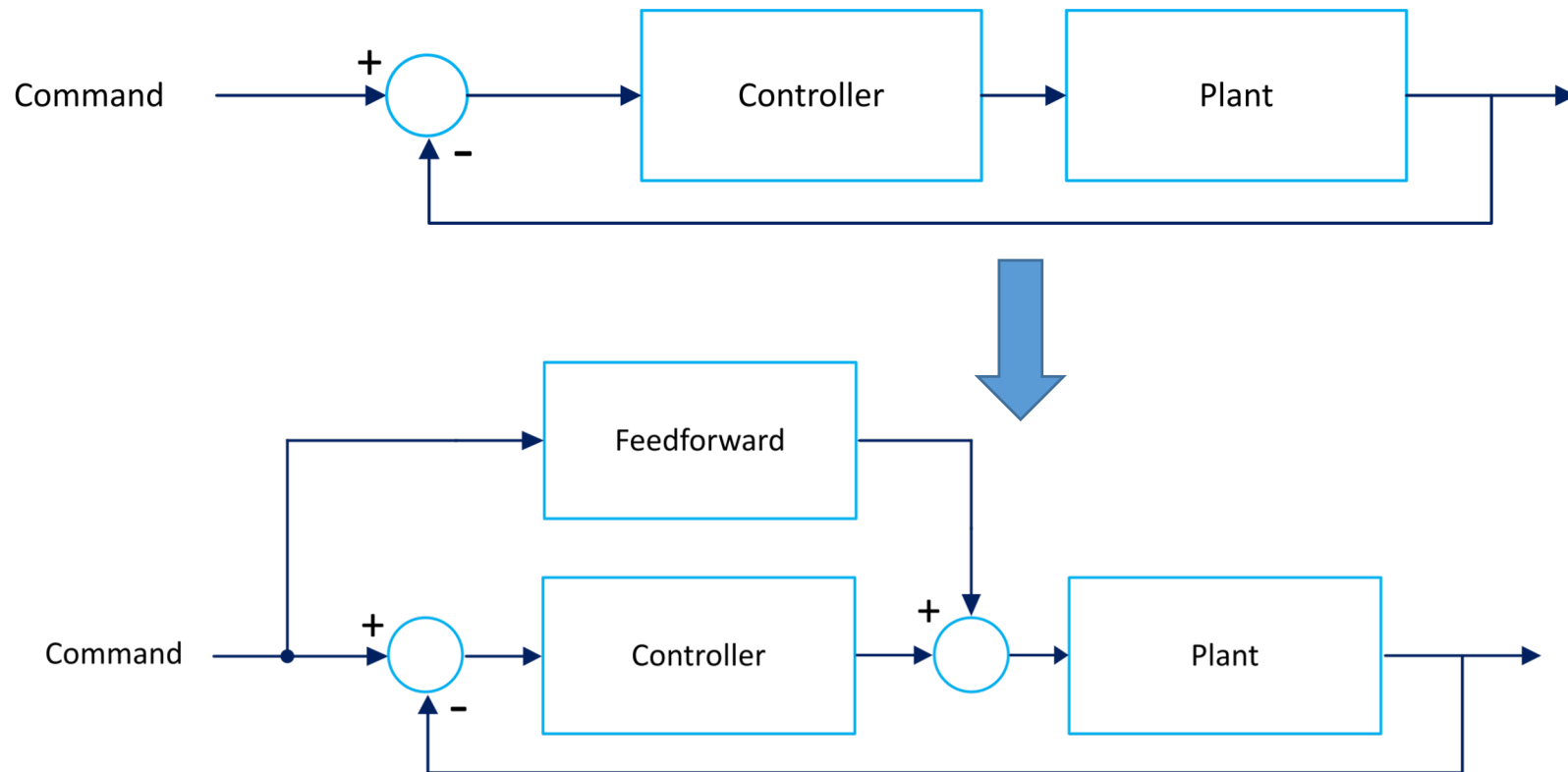

Feedforward Control Applications

Some common applications include

- Gravity compensation for manipulator arms
- Compensation for constant outlet flow in level-controlled tanks
- Temperature compensation for tanks with a constant flow
- Temperature control for HVAC based on time of day, outside temperature, etc.
- Pitch control of an airplane rudder based on ground speed

Takeaways - Feedforward control

- is used as an add-on to a conventional feedback controller to compensate for disturbances
- The approach is typically applied to modelled systems to allow the controller to focus its action on dynamic disturbances or changes in the setpoint
- The goal is typically to reduce the required control effort and thus improve the efficiency of the controller

Hybrid Control

- Hybrid control is used when *different controllers* need to be applied to the same plant at *different times*
- Hybrid systems are controlled in a similar way to finite state machines, with the control approach chosen based on the current and desired state of the system
- The controllers that are substituted depending on the state can be completely different in their approach to controlling the plant, and even act on different actuators (e.g. heater vs cooler)

Hybrid Systems

- In this example, two approaches are required to controlling the temperature of a room; a heater for raising the temp, and a cooler for lowering the temp when it is too high.
- The two controllers are substituted into the system depending on the desired state and current state of the system

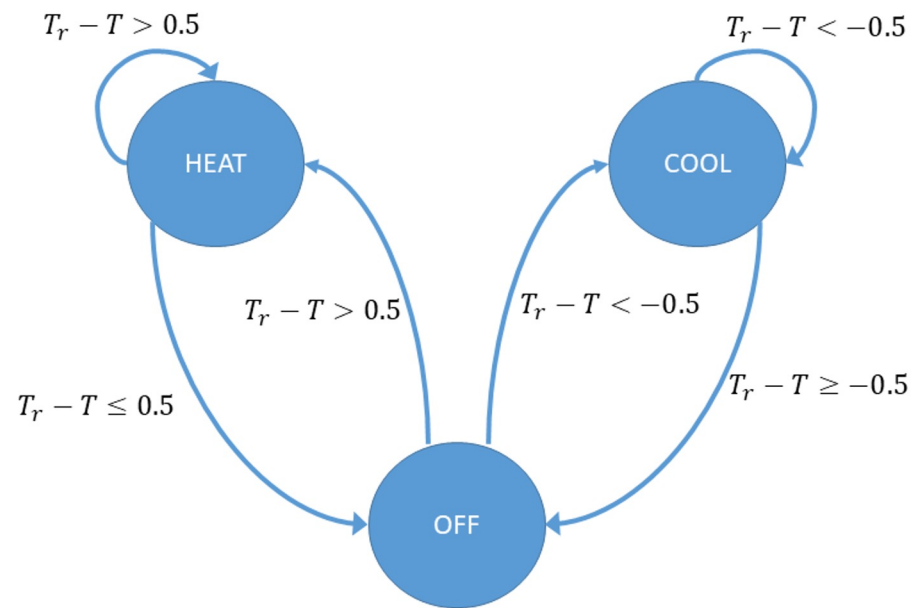

Hybrid control

Example: HVAC System

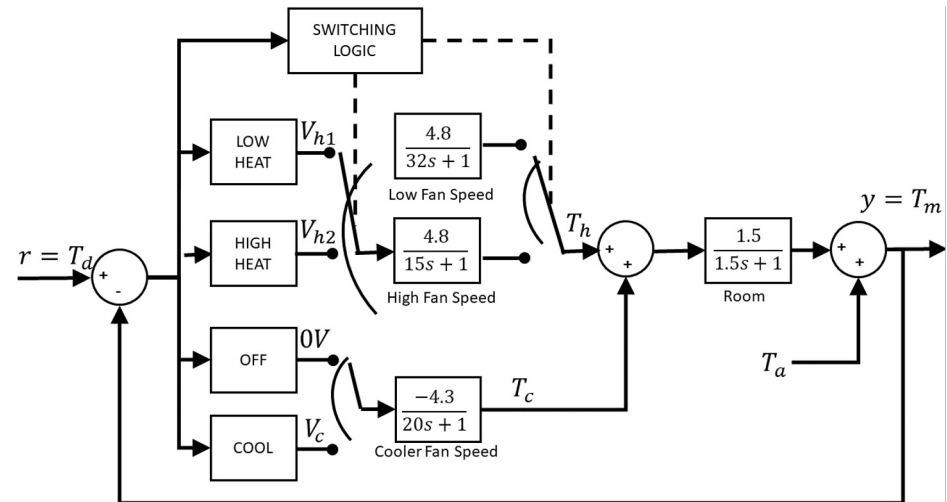
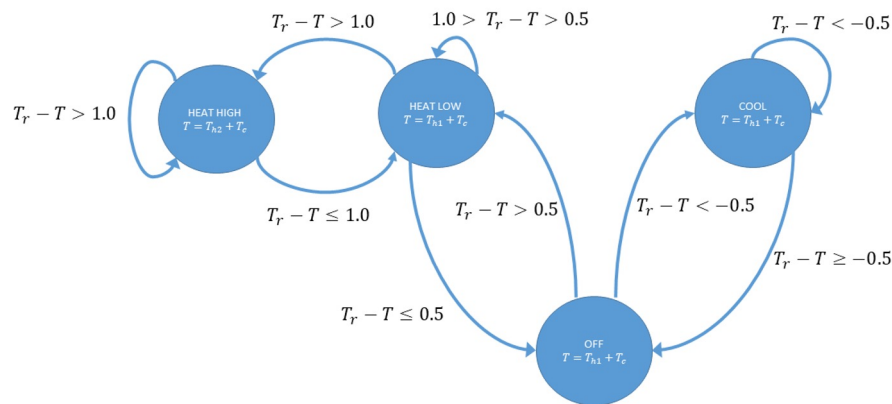

In this example we take the heating and cooling example a little further by introducing a more complex system where the system has a heater, cooler, and variable speed fan. The different elements of the system require different control strategies and even actuators, and thus hybrid control is a perfect fit.

Hybrid Control Applications

- Convection oven
- HVAC system
- Water filtration and dispensing system
- Washing machines
- Many industrial processes



Takeaways - Hybrid control

- Whereas cascade control is used to combine multiple controllers for connected parts of a system, and feedforward is used to add additional control action to a single controller, hybrid control is used to completely substitute separate controllers depending on the state of a system.
- Hybrid control is a very common approach to the control of automated systems
- The field of hybrid control is very active, and this material only represents an introduction to the concepts and approaches.